

PRODUCT BROCHURE:

# HRS UNICUS SERIES

## SCRAPED SURFACE HEAT EXCHANGERS



# HRS UNICUS SERIES

## HRS UNICUS SERIES - FOOD

### The solution for applications with delicate products

The patented design is based on a traditional shell and tube heat exchanger with scraping elements inside each tube. The reciprocating movement of the scrapers mixes the fluid while cleaning the heat exchange surface. This keeps heat transfer high and reduces downtime. In addition, the scraping movements introduce turbulence in the fluid increasing levels of heat transfer.

This design makes the HRS Unicus Series the ideal heat exchanger for sanitary applications where fouling or low heat transfer is a limiting factor.

The gentle movement of the scrapers allows the system to be used with delicate products, such as whole fruit or vegetable pieces, without destroying the integrity.

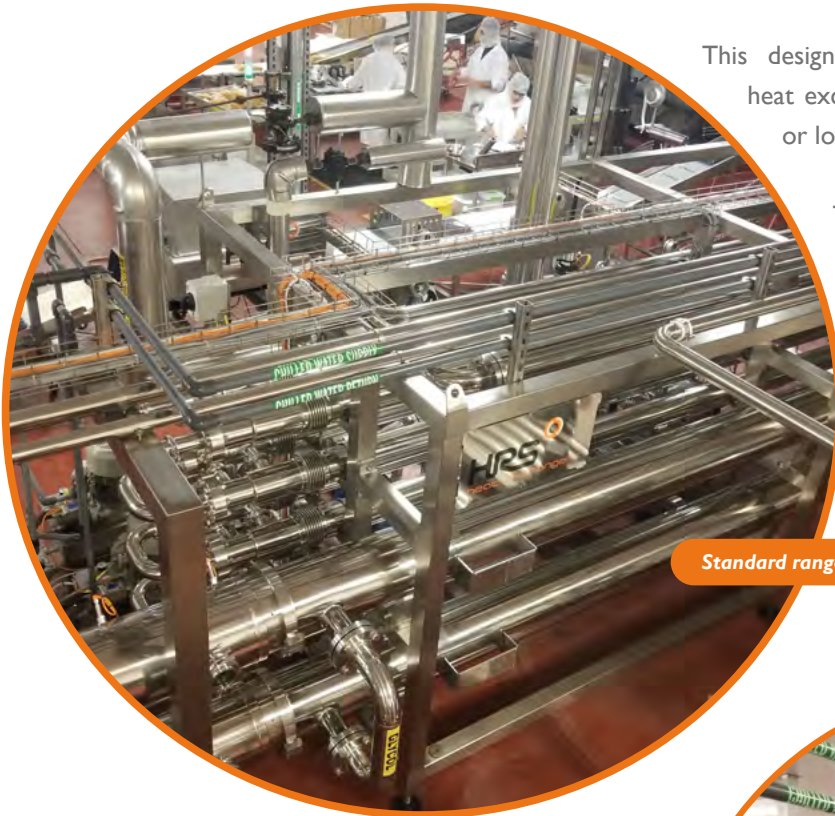

Standard range up to 108ft<sup>2</sup>

The effect of scraping is twofold, it ensures potential fouling is minimized by keeping the tube wall clean while enhancing turbulence and increasing the heat transfer rate. This patented design makes the Unicus an ideal heat exchanger for high fouling and viscous fluids.



The HRS Unicus installed in a sauce cooling skid



# HRS UNICUS SERIES

## HRS UNICUS SERIES - ENVIRONMENTAL



A special version of the Unicus has been developed for use in environmental applications. The patented design consists of a shell and tube heat exchanger with scraping rods in the interior tubes. During evaporation, fouling and reduced heat transfer can become a problem for traditional evaporators.

With the Unicus, the scraping action keeps the heat transfer surface clean and maintains high heat transfer, allowing the Unicus to concentrate to levels where traditional technologies fail.

The Unicus when used as an evaporator can be applied in a multi-effect setup or in combination with mechanical vapour recompression. The scrapers allow continuous operation and increases uptime of the plant.

The Unicus evaporator can operate under vacuum and is ideally suited for volume reduction of environmental waste and reducing transportation costs.

Unicus Series models are available from just one tube up to 198 tubes. This gives the HRS Unicus Series heat transfer areas between 7.5 and 1938ft<sup>2</sup>.



Heat transfer area up to 1938ft<sup>2</sup>

# HRS UNICUS SERIES

## FEATURES

### HYDRAULIC DRIVE CYLINDER

This part provides the energy that moves the scraper bars. The cylinder can be pneumatic (smaller models) or hydraulic (bigger models).

### SEPARATION CHAMBER

This separates the shell and tube heat exchanger from the drive cylinder that moves the scraper bars.

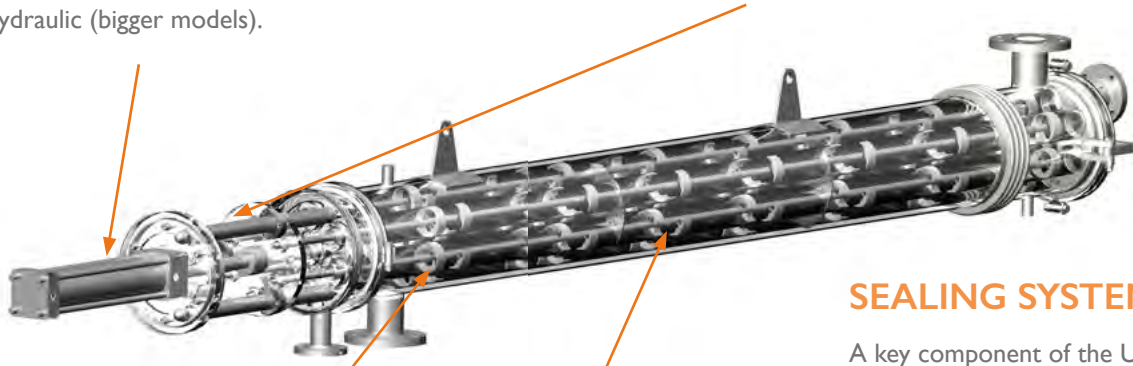

### SCRAPER BARS

Inside each interior tube, a scraper bar is fitted, which can move along the longitudinal axis of the tube.

### SEALING SYSTEM

A key component of the Unicus Series is the seal that separates the inner tube volume from the separation chamber. The seal prevents leakage of the product to the exterior. Several types of seals have been developed depending on the application.

### SCRAPERS

Designed to be lightweight, resistant to the working environment and thermally efficient in order to allow easy movement of the scraping bars, reducing the weight of the unit and lowering its energy consumption.

### Range of different scrapes available:



Scraper 120°  
mechanised



Scraper 180°  
mechanised



Scraper 180°  
compact



Scraper 360° with 3 holes



Scraper 360° with 3 holes  
and a peek ring



Scraper 360° with 6 holes  
and a peek ring

### Some of the unique features of the Unicus Series include:

- Larger heat transfer area per unit
- Maintained product identity
- Increased uptime
- Reduced footprint
- Suitable for highly viscous fluids

# HRS UNICUS SERIES

## STANDARD SPECIFICATIONS

**MATERIALS:**

Service Side: AISI 304 Stainless Steel

Product Side: AISI 316 Stainless Steel

*Other material options available*

**CONNECTIONS:**

Service Side: Clamp/Flange

Product Side: Clamp/Flange

*All flange & clamp types available*

**SURFACE FINISH:**

External: Polished

Internal: <0.8μ

**DESIGN CONDITIONS:**

Service Side: 147 PSI/365°F

Product Side: 232 PSI/365°F



Scrapers

## APPLICATIONS

The HRS Unicus Series is suitable for heat transfer applications in a wide range of industries including:

- Dairy
- Fruits
- Vegetables
- Convenience Food
- Protein
- Confectionary
- Beverages
- Cosmetics
- Environmental Waste
- Biofuels
- Oil & Gas





**HRS UK**

+44 1923 232 335

**HRS Spain**

+34 968 676 157

**HRS USA**

+1 770 726 3540

**HRS Malaysia**

+60 3 8081 1898

**HRS India**

+91 20 2566 3581

**HRS Australia**

+61 3 9489 1866

**HRS New Zealand**

+64 9 889 6045





PRODUCT BROCHURE:  
**HRS R SERIES**  
SCRAPED SURFACE HEAT EXCHANGERS



# HRS R SERIES

---

## The solution for high value viscous applications

The HRS R Series is a rotary scraped surface heat exchanger developed for sanitary applications. Each inner tube contains a scraper bar fitted with a helical screw which rotates at high speed and enhances flow through the tube whilst reducing pressure drop. Furthermore, the continuous scraping action eliminates fouling on the inner tube wall, ensuring that the heat transfer area is clean at all times.

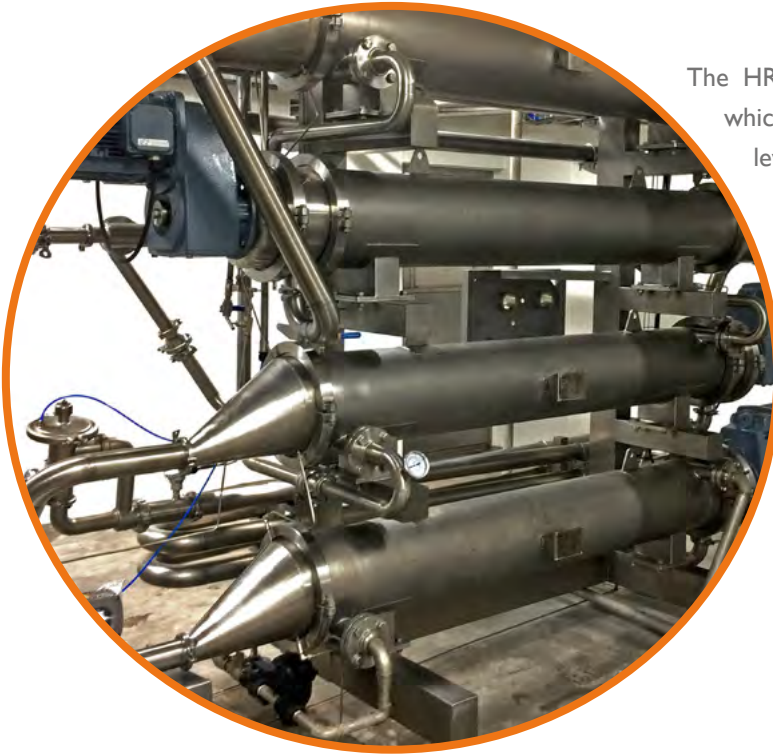

The HRS R Series technology uses a rotary scraper bar, which can reach speeds of up to 300rpm resulting in high levels of shear and mixing at the heat transfer surface; dramatically increasing the heat transfer rate.

In addition to the standard HRS R Series, a heavy duty version is available. The HRS RHD has been developed for more demanding applications and has all the benefits of the standard model. Features include a more powerful self-supported motor, larger scraper bar and additional scraper supports which enable the unit to be used under extreme conditions.

## Some of the unique features of the HRS R Series include:

- Large heat transfer area
- Single and multiple tube options, all with removable tubes
- Reduced pressure drop
- High level of product recovery
- Low noise level gearbox
- Energy efficient
- Multipass version available



The HRS R Series is the ideal solution for high value viscous applications such as honey, molasses, custards and creams, where fouling or low heat transfer is a problem.



# HRS R SERIES

## FEATURES

### GEARBOX SYSTEM

Unlike other rotating scraped surface heat exchangers, the HRS R Series can use up to six heat transfer tubes in a single unit. This is made possible using a uniquely engineered gearbox system which transfers the energy of a single electrical motor to the scraper rods in each individual tube. In this way, a greater surface area can be fitted in a single unit. The gearbox design also gives the benefit of low noise level during operation due to the materials of construction.

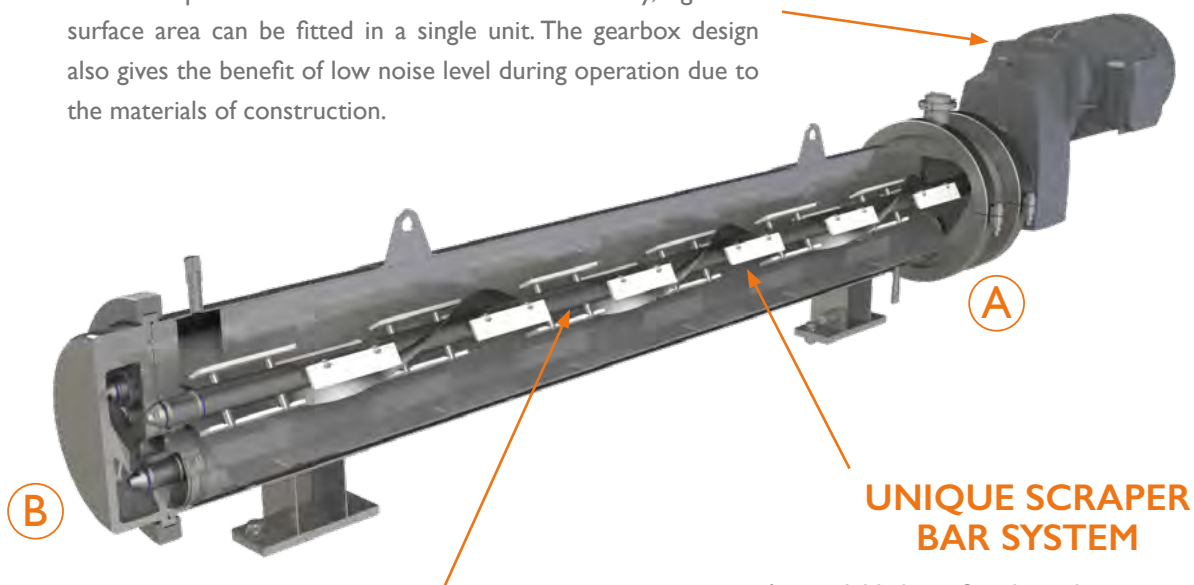

### REMOVABLE INNER TUBES

The HRS R Series is fitted with removable inner tubes, each tube has a single mechanical seal at position **A** and guide ring at position **B**. Easy inspection and maintenance significantly reduces operational costs.

### UNIQUE SCRAPER BAR SYSTEM

A spiral blade is fitted to the scraper bar. The rotating movement of this blade helps to push the fluid forward. This way, highly viscous fluids are pumped through the heat exchangers more easily resulting in less back pressure.

### BAFFLE PLACEMENT

The design of the HRS R Series allows one or multiple heat transfer tubes to be fitted into one single heat exchanger shell, increasing the size of the shell side cross section. If the liquid shell side flow is limited then velocities, and therefore heat transfer are reduced on the shell side. To improve this, longitudinal baffles are fitted to separate the fluid paths in the shell; acting as an individual compartment for each heat transfer tube. The flow cross section is reduced and velocities increase, maintaining heat transfer rates. For multipass designs, complete counter-current flow between the shell side fluid and tube side fluid can be obtained.

In case of condensing (for example steam heating) or evaporating (for example ammonia cooling) fluids, the units can be designed without longitudinal baffles for better performance.

# HRS R SERIES

## FEATURES

Unique gearbox design  
reduces noise level

Multitubes are fitted into  
a single shell giving more  
heat transfer area

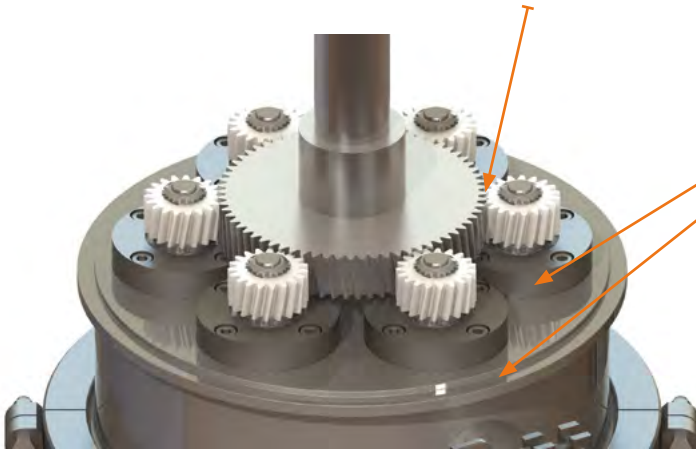

### ROTATION:

Scrapers keep heat transfer walls clean

### HELIX MIXING SPIRAL:

Reduces pressure drop  
and can be run in reverse  
for enhanced product  
recovery

### PRODUCT FLOW:

Reduced fouling, good  
product identity and  
reduced pressure drop

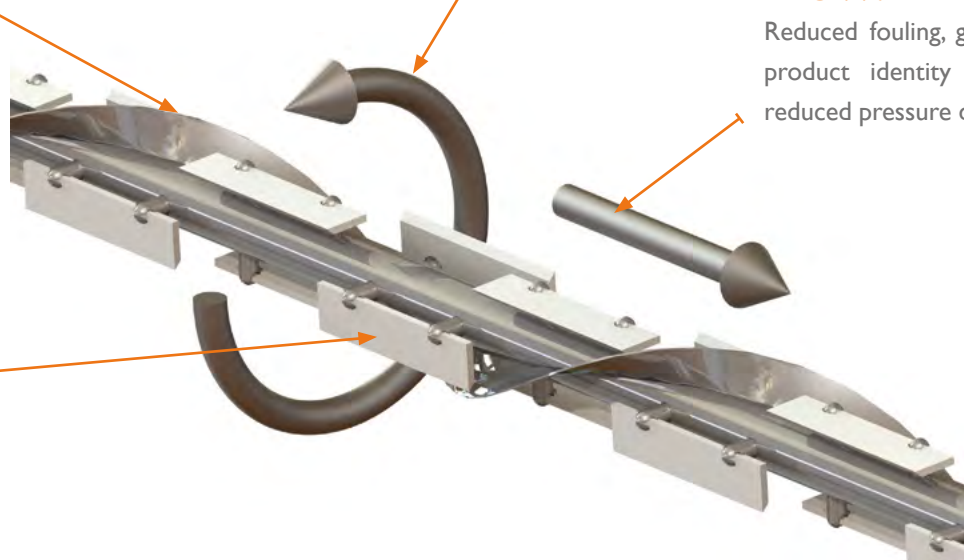

### SCRAPER:

Scrapers are available in a  
metal detectable material

### SEALING SYSTEM

This HRS R Series is fitted with a unique  
sealing system which enables the removal of  
individual tubes, resulting in easy servicing and  
replacement. This unique feature leads to a  
significant reduction in operating costs.



# HRS R SERIES

## STANDARD SPECIFICATIONS

### MATERIALS:

Service Side: AISI 304 Stainless Steel  
Product Side: AISI 316L Stainless Steel

*Other material options available*

Scrapers: PEEK, Metal Detectable PEEK  
Gaskets: EPDM, Viton, PTFE  
Mechanical Seals: Carbon Silicon Carbide, Tungsten Carbide

### CONNECTIONS:

Service Side: Clamp/Flange  
Product Side: Clamp

*All flange & clamp types available*

### SURFACE FINISH:

External: Polished  
Internal:  $<0.8\mu$

### DESIGN CONDITIONS:

Service Side: 145 PSI/365°F  
Product Side: 305 PSI/365°F

### POWER:

Standard R Series: 5.4 hp - 40hp  
Heavy Duty RHD Series: 10hp - 74hp



## APPLICATIONS

The HRS R Series is suitable for heat transfer applications for very wide range of products including:

- Viscous Food Products
- Convenience Foods
- Protein
- Cosmetics
- Oil & Gas







**HRS UK**

+44 1923 232 335

**HRS Spain**

+34 968 676 157

**HRS USA**

+1 770 726 3540

**HRS Malaysia**

+60 3 8081 1898

**HRS India**

+91 20 2566 3581

**HRS Australia**

+61 3 9489 1866

**HRS New Zealand**

+64 9 889 6045