

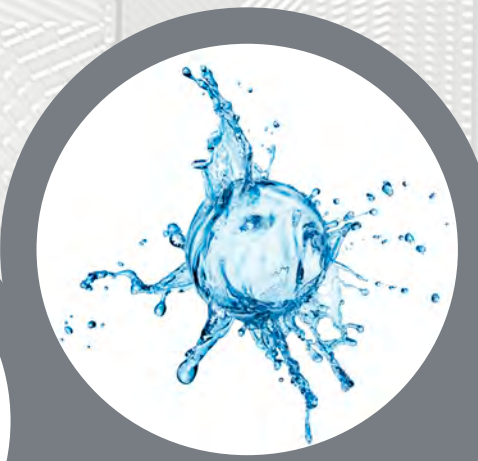

PRODUCT BROCHURE:  
**HRS PHE SERIES**  
PLATE HEAT EXCHANGERS



# HRS PHE SERIES

## PLATE HEAT EXCHANGERS



Plate Heat Exchangers (PHEs) are the ideal solution for heat transfer applications where product viscosities, particulates, temperatures and pressures are relatively low.

The highly efficient design also makes them an ideal choice where the required product outlet temperature is close to the service inlet temperature (close temperature approach), keeping the heat exchanger compact and cost effective.

PHEs consist of a series of thin pressed metal plates packed inside a frame. The product and service fluids fill alternate channels throughout the unit with heat being transferred across each plate - the two fluids do not come into direct contact with each other.

All HRS Plate Heat Exchangers are designed to have the correct thermal length for the duty required ensuring optimum performance, minimal fouling and maximum service life. Different plate patterns are available to ensure the correct thermal heat transfer is achieved in the most cost-effective configuration.

### Advantages:

- Highly efficient - compact design/small footprint
- Suitable for close approach temperatures
- Low cost solution
- Demountable (gasketed only) - good access for cleaning/servicing product and service sides
- Can be modified (gasketed only) - easy to extend/reduce plate pack if duty parameters change

### Limitations:

- Maximum temperature and pressure limited by gasket material
- Narrow plate gap highly efficient but not suitable for fibres, particles or high viscosities



*Where PHEs are not suitable please see our wide range of HRS corrugated tubular and scraped surface heat exchangers designed specifically for more demanding applications.*

# HRS PHE SERIES

## GASKETED HEAT EXCHANGERS

Gasketed PHEs use a rubber gasket to create a seal between each plate in the plate pack. Unlike fully welded/brazed heat exchangers this makes the heat exchanger fully demountable. The frame can be opened and heat transfer plates separated to allow complete refurbishment of the heat exchanger (clean & crack test plates, re-gasket and re-build).

As gasketed PHEs are fully demountable they can also be easily modified - if the duty requirement changes plates can be added or removed to suit. Our design engineers are available to carry out re-designs and our service team are available to fit the new plate pack required.

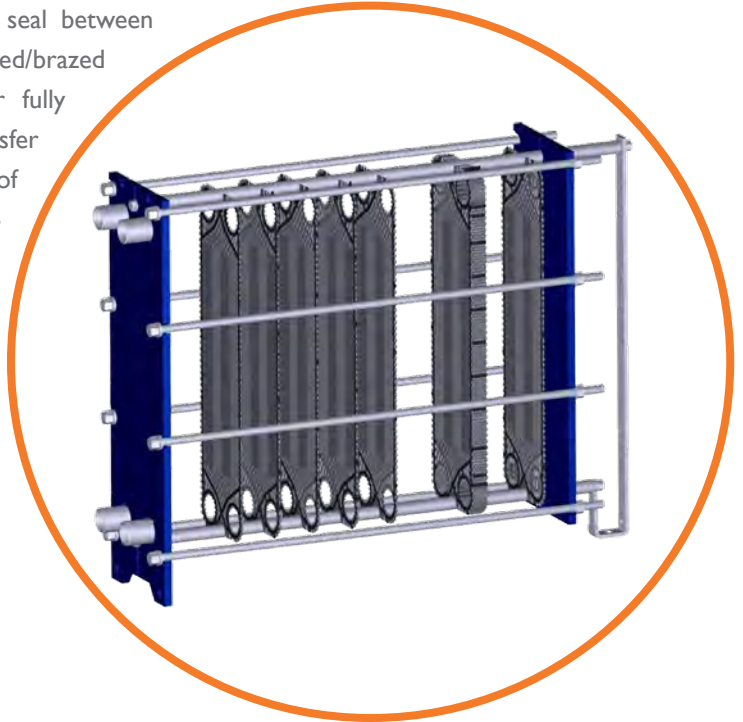

### FRAME MATERIAL

The most cost-effective frame material for industrial applications is painted carbon steel. For hygienic applications stainless steel frames can be supplied including all stainless steel frame parts and a wide range of hygienic connections.

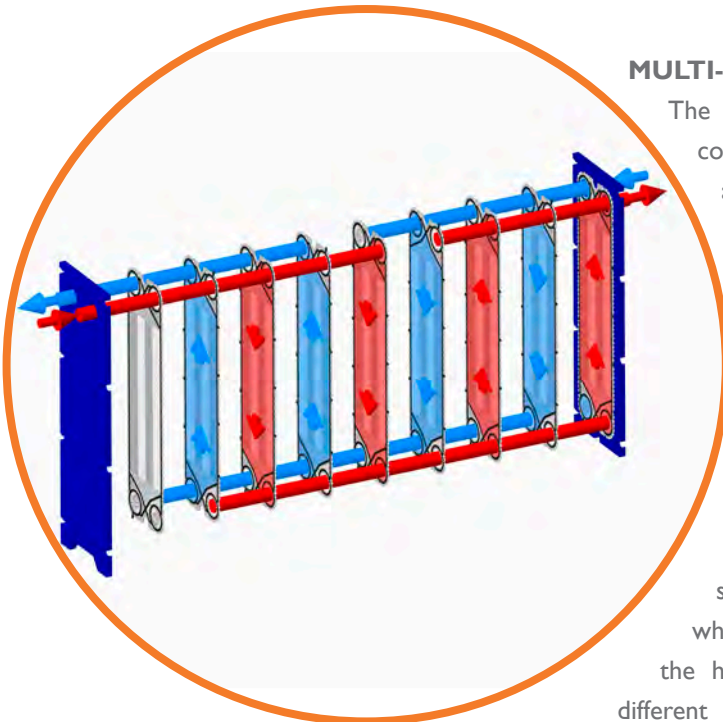

### MULTI-PASS DESIGN

The standard PHE design is 'single pass' with all four connections on one frame plate. However, for certain applications it is preferable to have a 'multi-pass' design, effectively creating two or more plate packs within one frame. This is achieved by adding special 'turning' plates within the pack to create more than one pass of the process fluids. Multi-pass designs have connections on both ends of the heat exchanger.

### MULTI-STAGE DESIGN

Multi-stage heat exchangers are used to combine several applications, or process 'stages', into a single heat exchanger. Unlike the multi-pass option, where the two process fluids remain the same through the heat exchanger, a multi-stage heat exchanger allows different service fluids to be used in different sections e.g. heating, regeneration and cooling can all be achieved in one multi-stage heat exchanger maximising efficiency and minimising footprint and cost.

# HRS PHE SERIES

## SAFE DESIGN



Gaskets are designed with a port ring and a cross bar to create a **'double seal'** around the port to prevent mixing of the fluids – any gasket failure will result in a leak to atmosphere rather than cross contamination. In standard units with single wall plates the only way cross contamination can occur is if a plate fails (crack or pin-hole).

For certain food and pharmaceutical applications **double wall safety plates** are used to **prevent cross-contamination**. Pairs of plates are laser-welded around the port holes. This creates a 'safety gap' between the plates – if a plate is cracked or pin-holed the process fluid will leak into this gap and to atmosphere instead of crossing into the other fluid. Any leaks detected signal it is time to service the heat exchanger.

## SPARES AND SERVICE

HRS has its own dedicated spares and service company, HeatExchangerSpares.com, and holds an extensive stock of plates and gaskets. Our team of service engineers are available to service all brands of Plate Heat Exchanger.

### Why choose HRS?

- Competitive Pricing
- Fast Response & Delivery
- 40 years experience
- Extensive Stock
- Experienced Service Engineers



# HRS PHE SERIES

## STANDARD SPECIFICATIONS

PHE TYPES:	Gasketed or Brazed
FRAME MATERIALS:	Mild Steel (Epoxy Painted) Stainless Steel (solid or clad mild)
PLATE MATERIALS:	Stainless Steel AISI 304 (EN 1.4301) Stainless Steel AISI 316L (EN 1.4404) Titanium (Grade 1) Alloy 254 SMO (EN 1.4547) <i>Others available on request</i>
GASKET MATERIALS:	NBR, EPDM, FPM, HNBR, <i>Others available on request</i>
CONNECTIONS:	Threaded Grooved Pipe (Victaulic) Welded Flanges, Loose Flanges EN PN16-40 or ANSI 150-300lbs Studded Ports – unlined, AISI 316 lined or rubber lined EN 1092-1 Tri-Clamps (Imperial and Metric) Sizes: DN32, DN50, DN65, DN100, DN150, DN200



## APPLICATIONS

The HRS PHE Series is suitable for the following products and applications:

### APPLICATIONS

- Heating
- Cooling
- Pasteurisation
- Regeneration/Energy Recovery

### PRODUCTS

- Water, Juices, Milk
- Beer, Wort, Spirits
- Water for Injection (WFI)
- Industrial & Food Oils
- Chemicals





**HRS UK**

+44 1923 232 335

**HRS Spain**

+34 968 676 157

**HRS USA**

+1 770 726 3540

**HRS Mexico**

+52 55 8095 3306

**HRS Malaysia**

+60 3 8081 1898

**HRS India**

+91 20 2566 3581

**HRS Australia**

+61 3 9489 1866

**HRS New Zealand**

+64 9 889 6045