



**HRS**

PRODUCT BROCHURE:

# **HRS UNICUS SERIES**

SCRAPED SURFACE HEAT EXCHANGERS



# HRS UNICUS SERIES

## HRS UNICUS SERIES - FOOD

### The solution for applications with delicate products

The patented design is based on a traditional shell and tube heat exchanger with scraping elements inside each tube. The reciprocating movement of the scrapers mixes the fluid while cleaning the heat exchange surface. This keeps heat transfer high and reduces downtime. In addition, the scraping movements introduce turbulence in the fluid increasing levels of heat transfer.

This design makes the HRS Unicus Series the ideal heat exchanger for sanitary applications where fouling or low heat transfer is a limiting factor.

The gentle movement of the scrapers allows the system to be used with delicate products, such as whole fruit or vegetable pieces, without destroying the integrity.

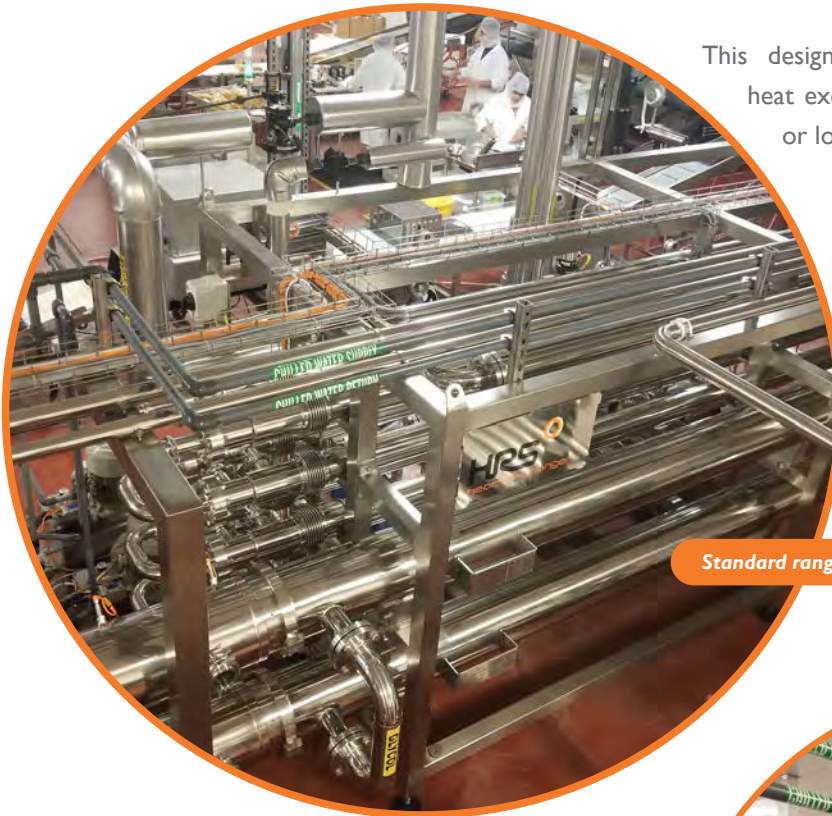

Standard range up to 108ft<sup>2</sup>

The effect of scraping is twofold, it ensures potential fouling is minimized by keeping the tube wall clean while enhancing turbulence and increasing the heat transfer rate. This patented design makes the Unicus an ideal heat exchanger for high fouling and viscous fluids.



The HRS Unicus installed in a sauce cooling skid



# HRS UNICUS SERIES

## HRS UNICUS SERIES - ENVIRONMENTAL



A special version of the Unicus has been developed for use in environmental applications. The patented design consists of a shell and tube heat exchanger with scraping rods in the interior tubes. During evaporation, fouling and reduced heat transfer can become a problem for traditional evaporators.

With the Unicus, the scraping action keeps the heat transfer surface clean and maintains high heat transfer, allowing the Unicus to concentrate to levels where traditional technologies fail.

The Unicus when used as an evaporator can be applied in a multi-effect setup or in combination with mechanical vapour recompression. The scrapers allow continuous operation and increases uptime of the plant.

The Unicus evaporator can operate under vacuum and is ideally suited for volume reduction of environmental waste and reducing transportation costs.

Unicus Series models are available from just one tube up to 198 tubes. This gives the HRS Unicus Series heat transfer areas between 7.5 and 1938ft<sup>2</sup>.



Heat transfer area up to 1938ft<sup>2</sup>

# HRS UNICUS SERIES

## FEATURES

### HYDRAULIC DRIVE CYLINDER

This part provides the energy that moves the scraper bars. The cylinder can be pneumatic (smaller models) or hydraulic (bigger models).

### SEPARATION CHAMBER

This separates the shell and tube heat exchanger from the drive cylinder that moves the scraper bars.

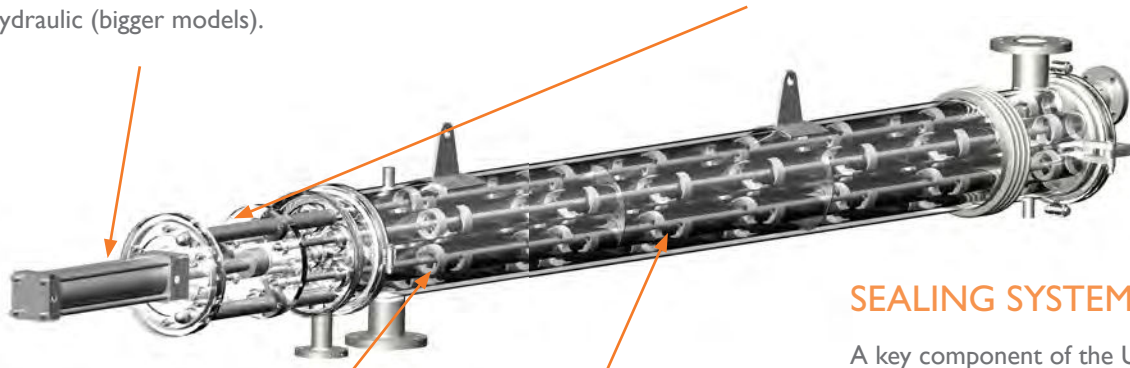

### SCRAPER BARS

Inside each interior tube, a scraper bar is fitted, which can move along the longitudinal axis of the tube.

### SEALING SYSTEM

A key component of the Unicus Series is the seal that separates the inner tube volume from the separation chamber. The seal prevents leakage of the product to the exterior. Several types of seals have been developed depending on the application.

### SCRAPERS

Designed to be lightweight, resistant to the working environment and thermally efficient in order to allow easy movement of the scraping bars, reducing the weight of the unit and lowering its energy consumption.

### Range of different scrapes available:



Scraper 120°  
mechanised



Scraper 180°  
mechanised



Scraper 180°  
compact



Scraper 360° with 3 holes



Scraper 360° with 3 holes  
and a peek ring



Scraper 360° with 6 holes  
and a peek ring

### Some of the unique features of the Unicus Series include:

- Larger heat transfer area per unit
- Maintained product identity
- Increased uptime
- Reduced footprint
- Suitable for highly viscous fluids

# HRS UNICUS SERIES

## STANDARD SPECIFICATIONS

### MATERIALS:

Service Side: AISI 304 Stainless Steel

Product Side: AISI 316 Stainless Steel

*Other material options available*

### CONNECTIONS:

Service Side: Clamp/Flange

Product Side: Clamp/Flange

*All flange & clamp types available*

### SURFACE FINISH:

External: Polished

Internal:  $<0.8\mu$

### DESIGN CONDITIONS:

Service Side: 147 PSI/365°F

Product Side: 232 PSI/365°F



Scrapers

## APPLICATIONS

The HRS Unicus Series is suitable for heat transfer applications in a wide range of industries including:

- Dairy
- Fruits
- Vegetables
- Convenience Food
- Protein
- Confectionary
- Beverages
- Cosmetics
- Environmental Waste
- Biofuels
- Oil & Gas





**HRS UK**

+44 1923 545 625

**HRS Spain**

+34 968 676 157

**HRS USA**

+1 770 726 3540

**HRS Mexico**

+52 55 8095 3306

**HRS Malaysia**

+60 3 8081 1898

**HRS India**

+91 20 2566 3581

**HRS Australia**

+61 3 9489 1866

**HRS New Zealand**

+64 9 889 6045

U2307US

[www.hrs-heatexchangers.com](http://www.hrs-heatexchangers.com)