



HRS



PRODUCT BROCHURE:
HRS AD & BIOGAS

HRS AD & BIOGAS SOLUTIONS

INTRODUCTION

Digestate Management

HRS offers pasteurisation and concentration technology for the efficient management of digestate:

- **Digestate Pasteurisation Systems (DPS):**
Continuous three tank pasteurisation of digestate with minimum energy investment.
- **Digestate Concentration Systems (DCS):**
A system that can reduce the volume of digestate to 20%, or less, of its original volume.
- **Biogas Dehumidification Systems (BDS):**
A system that removes water from biogas, protecting combined heat and power (CHP) engines from corrosion and cavitation.

Solutions are tailored for each biogas plant. **The DPS or DCS can be individually selected or combined**, depending on several factors such as: suitable thermal energy, digestate use, waste volume.

Our digestate management solutions offer the following advantages:

- Digestate is efficiently pasteurised to ensure it can be used safely for fertilisation.
- Digestate volume is significantly reduced, lowering the cost of transporting digestate off-site.
- Waste heat sources, such as heat from the CHP can be used as the energy source for both DPS and DCS processes.
- DPS and DCS (or a combination of both) can convert digestate from a stream of waste to a value added product.



HRS 3 Tank Digestate Pasteurisation System (DPS) with heat regeneration

HEAT EXCHANGERS

Digester Heating

Our DTI heat exchangers offer reliable solutions and advantages for heating digesters:

- High heat transfer
- Long running times
- No product blockage
- Easy to clean
- Larger surface area/Smaller footprint
- Eliminates fouling



HRS DTI Series for Digester Heating

Gas Heat Recovery

The HRS G Series is an ideal heat exchanger for cooling exhaust gases. The corrugated tubes can work with smaller heat transfer areas than traditional smooth tube heat exchangers. Our G Series units can be integrated and used to deliver thermal energy from the CHP units to our DPS and DCS systems.



Exhaust Gas Cooler

HRS AD & BIOGAS SOLUTIONS

DIGESTATE PASTEURISATION SYSTEMS WITH HEAT RECOVERY



HRS has developed a continuous digestate pasteurisation process based on HRS DTI and DTR Series heat exchangers and a product holding section, for the destruction of pathogens.

The flow sheet below explains how the digestate is heated to its pasteurisation temperature (normally 70°C) using two DTI heat exchangers. The holding section consists

of three tanks, with each tank holding the amount of product to be processed within the holding period (normally one hour). The three tanks make it possible to constantly send and extract product from the holding section and recover energy between the hot pasteurised digestate and the cold incoming digestate.

Energy savings of up to 70% can be obtained compared to systems without heat recovery sections. **For different pasteurisation criteria, HRS can provide solutions with up to three holding tanks, or holding tubes** (less management time) **for pasteurisation systems with higher temperatures.**

For fouling fluids, we can combine the DTI Series with our scraped surface heat exchangers offering a solution that reduces down time for cleaning.

Where required by legislation or quality demands to control pathogens in digestate (for example when treating animal by-products or producing digestate to the various global quality standards such as PAS110, EC and Class A Biosolids) pasteurisation may be required at some stage during the anaerobic digestion process.

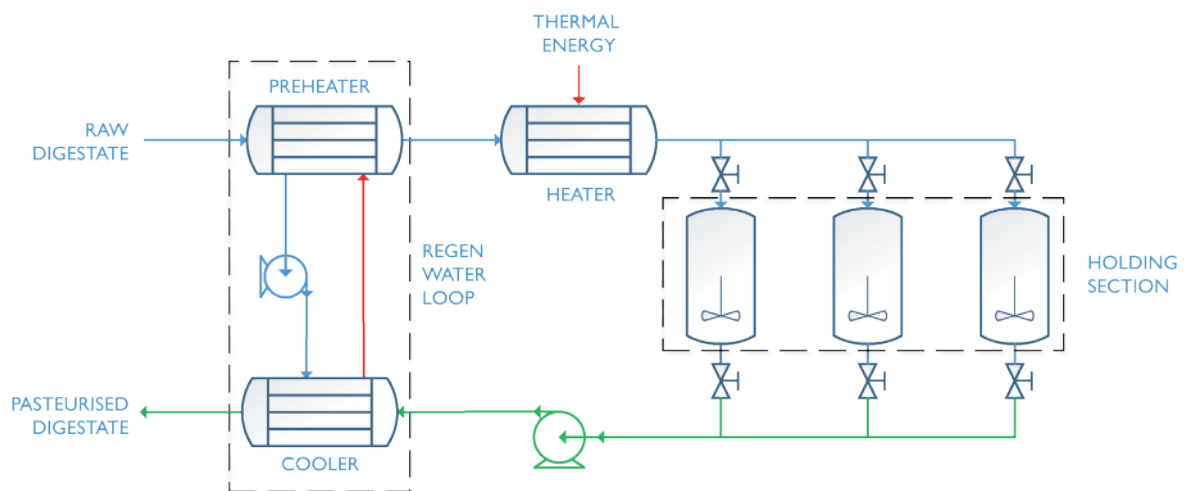

Continuous 3-Tank Pasteurisation System

HRS AD & BIOGAS SOLUTIONS

DIGESTATE CONCENTRATION SYSTEMS

Evaporation is an **efficient way of reducing the volume of digestate**. Our evaporation systems raise the digestate temperature to its boiling point; water is evaporated and condensed, thus obtaining a concentrated end product and water. **Forced recirculation:** a pump sends the product through the evaporator at high velocity. This process ensures heat transfer remains high and the negative effects of fouling are limited.



3 effect DCS installation

Corrugated Tube Digestate Concentration Systems

Using the **HRS K Series as an evaporator** module for the evaporation of low viscosity digestate with reduced particle size. **High heat transfer and good resistance against fouling.**

Other Applications: Wastewater, brines and effluents with organic solids in low concentration and with low to medium viscosities.



2 effect DCS installation

Scraped Surface Digestate Concentration Systems

Using the **Unicus Series as an evaporator** module for high fouling digestate with elevated viscosities. When concentrating to a high dry solid percentage the risk of fouling and high viscosity (low heat transfer) become apparent. For these applications, the patented Unicus is ideal due to its self-cleaning scraper action.

Other Applications: Effluents with high fouling risk and organic solids with high dry matter concentration.

These systems combine various evaporation stages. The vapour obtained from a previous stage is used as the thermal energy source for the resulting stage. Multiple stages can be combined to reduce the energy consumption needed for the amount of water evaporated.

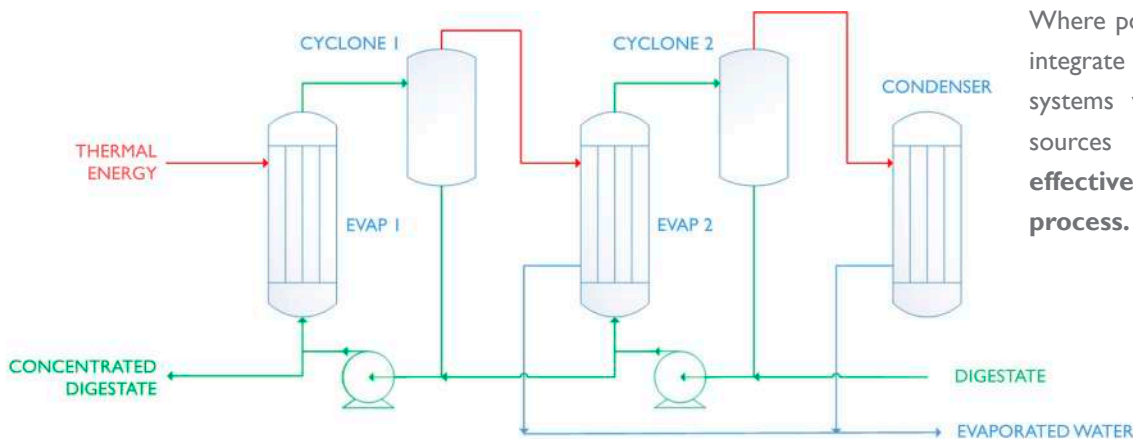

Two Effect Evaporation System Scheme

Where possible we aim to integrate our evaporation systems with waste heat sources **to achieve an effective sustainable process.**

HRS AD & BIOGAS SOLUTIONS

BIOGAS DEHUMIDIFICATION SYSTEMS

The HRS BDS Series is an efficient solution to cool and dehumidify biogas for combustion with two standard options. The system condenses up to 90% of the water contained in the gas, which is continuously separated before the clean biogas is ready for use. This is a necessary process for all bio-energy plants that use biogas as fuel in CHP engines.

A heat recovery step can be included as a standard option thus reducing energy costs up to 20%.

The BDS comes complete with controls in a packaged 'plug and play' skid.

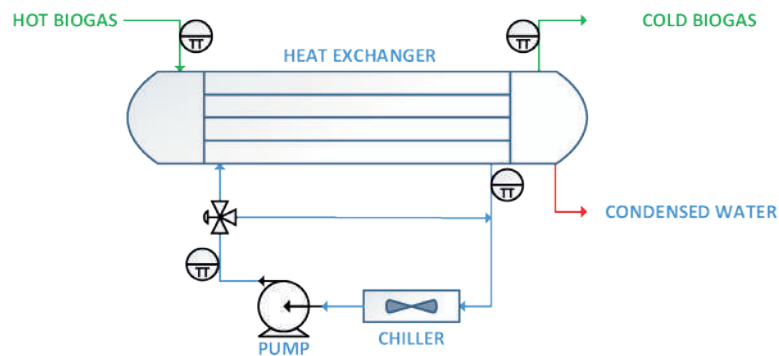

Standard Option

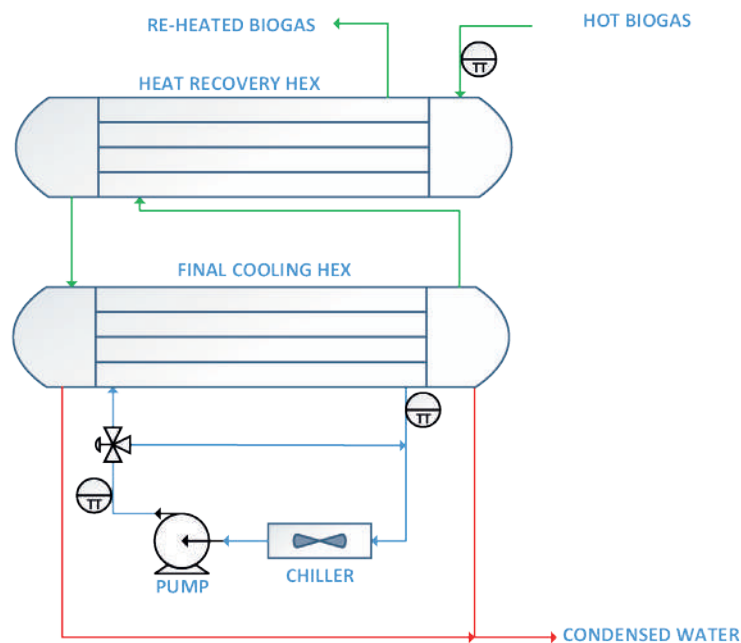

Heat Recovery Option



HRS UK

+44 1923 545 625

HRS Spain

+34 968 676 157

HRS USA

+1 770 726 3540

HRS Malaysia

+60 3 8081 1898

HRS India

+91 20 2566 3581

HRS Australia

+61 3 9489 1866

HRS New Zealand

+64 9 889 6045

AD2309EN

www.hrs-heatexchangers.com