

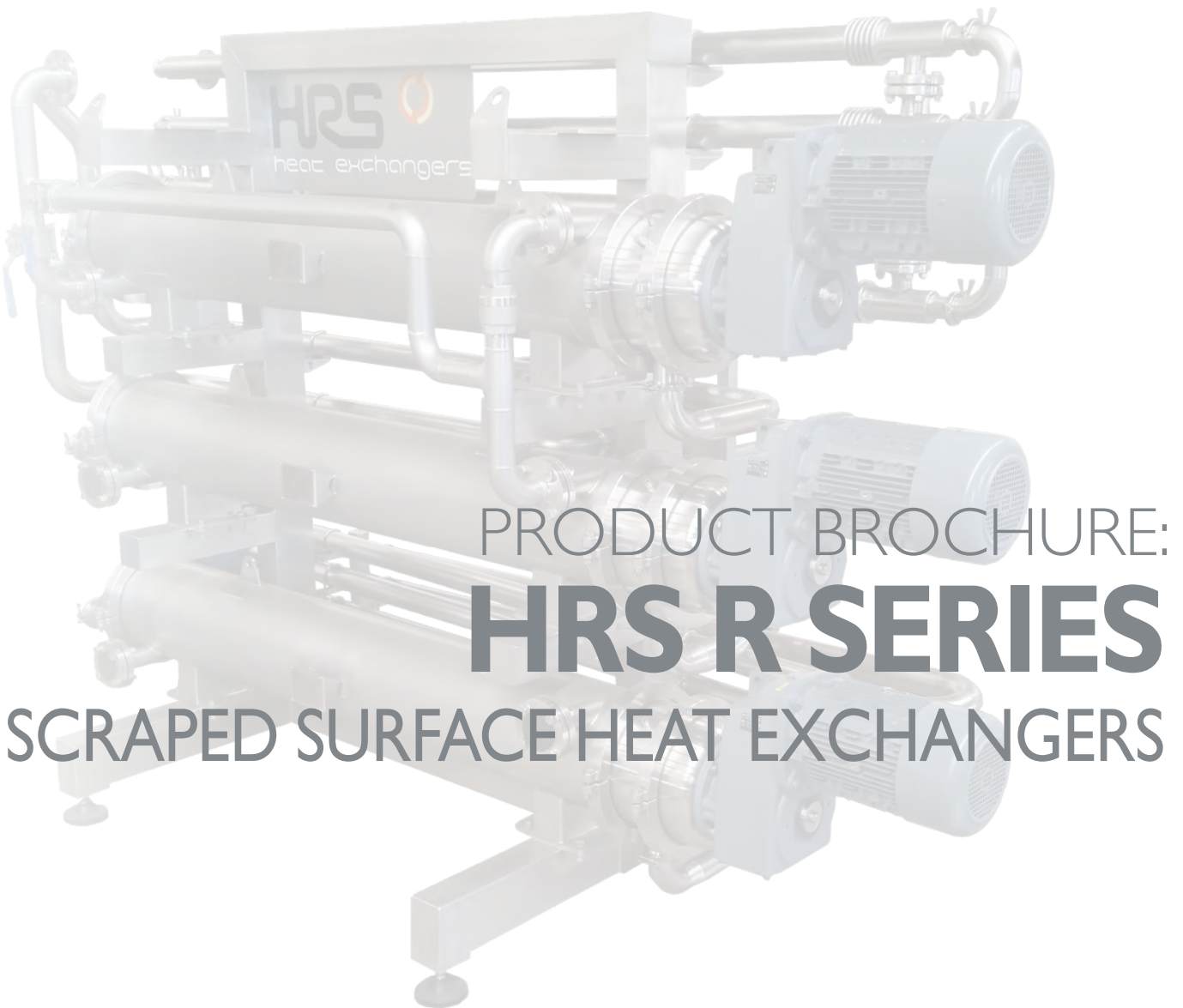

# HRS



PRODUCT BROCHURE:

# HRS R SERIES

## SCRAPED SURFACE HEAT EXCHANGERS



# HRS R SERIES

## The solution for high value viscous applications

The HRS R Series is a rotary scraped surface heat exchanger developed for sanitary applications. Each inner tube contains a scraper bar fitted with a helical screw which rotates at high speed and enhances flow through the tube whilst reducing pressure drop. Furthermore, the continuous scraping action eliminates fouling on the inner tube wall, ensuring that the heat transfer area is clean at all times.

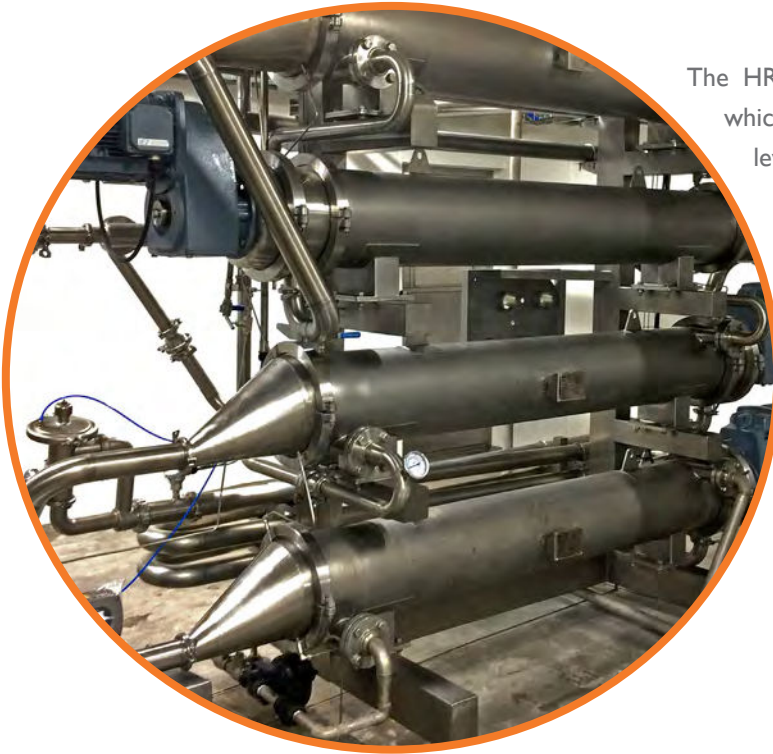

The HRS R Series technology uses a rotary scraper bar, which can reach speeds of up to 300rpm resulting in high levels of shear and mixing at the heat transfer surface; dramatically increasing the heat transfer rate.

In addition to the standard HRS R Series, a heavy duty version is available. The HRS RHD has been developed for more demanding applications and has all the benefits of the standard model. Features include a more powerful self-supported motor, larger scraper bar and additional scraper supports which enable the unit to be used under extreme conditions.

## Some of the unique features of the HRS R Series include:

- Large heat transfer area
- Single and multiple tube options, all with removable tubes
- Reduced pressure drop
- High level of product recovery
- Low noise level gearbox
- Energy efficient
- Multipass version available



The HRS R Series is the ideal solution for high value viscous applications such as honey, molasses, custards and creams, where fouling or low heat transfer is a problem.

# HRS R SERIES

## FEATURES

### GEARBOX SYSTEM

Unlike other rotating scraped surface heat exchangers, the HRS R Series can use up to six heat transfer tubes in a single unit. This is made possible using a uniquely engineered gearbox system which transfers the energy of a single electrical motor to the scraper rods in each individual tube. In this way, a greater surface area can be fitted in a single unit. The gearbox design also gives the benefit of low noise level during operation due to the materials of construction.

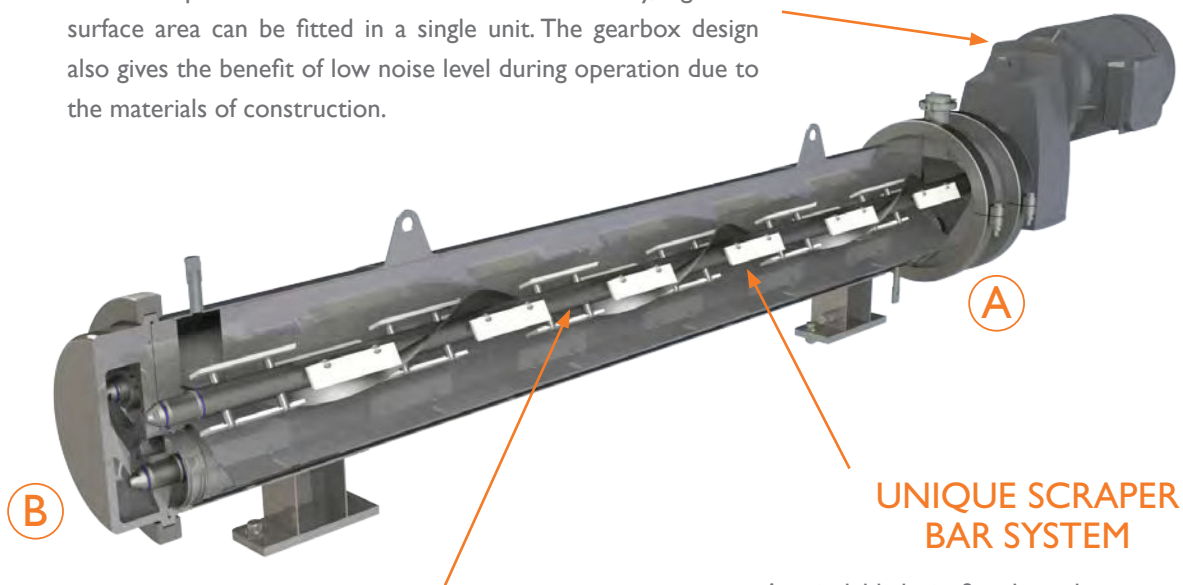

**B**

### REMOVABLE INNER TUBES

The HRS R Series is fitted with removable inner tubes, each tube has a single mechanical seal at position **A** and guide ring at position **B**. Easy inspection and maintenance significantly reduces operational costs.

### UNIQUE SCRAPER BAR SYSTEM

A spiral blade is fitted to the scraper bar. The rotating movement of this blade helps to push the fluid forward. This way, highly viscous fluids are pumped through the heat exchangers more easily resulting in less back pressure.

### BAFFLE PLACEMENT

The design of the HRS R Series allows one or multiple heat transfer tubes to be fitted into one single heat exchanger shell, increasing the size of the shell side cross section. If the liquid shell side flow is limited then velocities, and therefore heat transfer are reduced on the shell side. To improve this, longitudinal baffles are fitted to separate the fluid paths in the shell; acting as an individual compartment for each heat transfer tube. The flow cross section is reduced and velocities increase, maintaining heat transfer rates. For multipass designs, complete counter-current flow between the shell side fluid and tube side fluid can be obtained.

In case of condensing (for example steam heating) or evaporating (for example ammonia cooling) fluids, the units can be designed without longitudinal baffles for better performance.

# HRS R SERIES

## FEATURES

Unique gearbox design  
reduces noise level

Multitubes are fitted into  
a single shell giving more  
heat transfer area

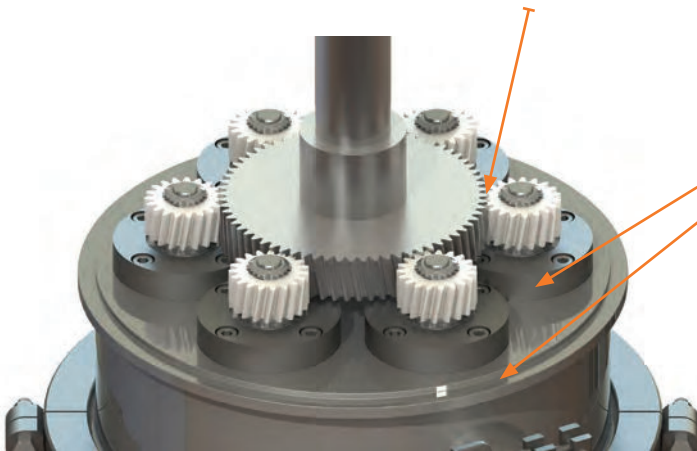

### ROTATION:

Scrapers keep heat transfer walls clean

### PRODUCT FLOW:

Reduced fouling, good  
product identity and  
reduced pressure drop

### HELIX MIXING SPIRAL:

Reduces pressure drop  
and can be run in reverse  
for enhanced product  
recovery

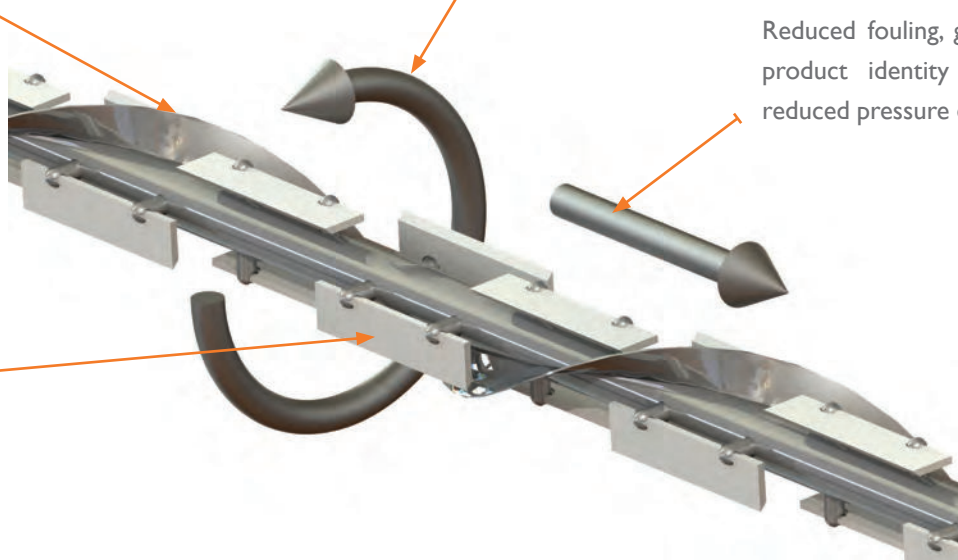

### SCRAPER:

Scrapers are available in a  
metal detectable material



### SEALING SYSTEM

This HRS R Series is fitted with a unique  
sealing system which enables the removal of  
individual tubes, resulting in easy servicing and  
replacement. This unique feature leads to a  
significant reduction in operating costs.

# HRS R SERIES

## STANDARD SPECIFICATIONS

### MATERIALS:

Service Side: AISI 304 Stainless Steel  
Product Side: AISI 316L Stainless Steel

*Other material options available*

Scrapers: PEEK, Metal Detectable PEEK  
Gaskets: EPDM, Viton, PTFE  
Mechanical Seals: Carbon Silicon Carbide, Tungsten Carbide

### CONNECTIONS:

Service Side: Clamp/Flange  
Product Side: Clamp

*All flange & clamp types available*

### SURFACE FINISH:

External: Polished  
Internal:  $<0.8\mu$

### DESIGN CONDITIONS:

Service Side: 145 PSI/365°F  
Product Side: 305 PSI/365°F

### POWER:

Standard R Series: 5.4 hp - 40hp  
Heavy Duty RHD Series: 10hp - 74hp



## APPLICATIONS

The HRS R Series is suitable for heat transfer applications for very wide range of products including:

- Viscous Food Products
- Convenience Foods
- Protein
- Cosmetics
- Oil & Gas





**HRS UK**

+44 1923 545 625

**HRS Spain**

+34 968 676 157

**HRS USA**

+1 770 726 3540

**HRS Malaysia**

+60 3 8081 1898

**HRS India**

+91 20 2566 3581

**HRS Australia**

+61 3 9489 1866

**HRS New Zealand**

+64 9 889 6045

R2309US

[www.hrs-heatexchangers.com](http://www.hrs-heatexchangers.com)